

FBO-10 and FBO-14

Fuel Filter/Water Separator For High-Flow Applications



These versatile housings have three filter options to meet various requirements: a fuel filter/water separator, a silicone treated filter, and a water absorber. For fuel dispensing applications the fuel filter/water separator filter is recommended.

FBO-10 and FBO-14 filter assemblies are designed to meet the toughest hydrocarbon refueling conditions and designed for easy cartridge changeouts.

The FBO assembly can be used on mobile refuelers or installed in refueling cabinets. The FBO unit can also be used for diesel fuel dispensing pumps, as a primary fuel filter/water separator for large diesel engines, or as bulk fuel handling, fuel transfer, and other higher flow applications.



Contact Information

Parker Hannifin Corporation
Racor Division
P.O. Box 3208
3400 Finch Road
Modesto, CA 95353

phone 800 344 3286
209 521 7860
fax 209 529 3278
racor@parker.com

www.racorcustomers.com
www.parker.com/racor

Product Features

- Die-cast aluminum head
- Steel filter bowl assembly
- Powder coated components
- Mounting bracket
- Locking ring collar “no V-clamps”
- 1.5” NPT inlet and outlet
- Viton® seals for compatibility to various fuels
- Designed to withstand a max pressure of 150 PSI (10 bar) and a max temperature of 240°F (115°C)
- Manual drain valve (1/4” NPT)
- Manual vent valve
- Sight glass (1/2” NPT)
- 120 volt AC explosion proof heater option available
- Wide variety of accessories, filters and applications available

Note: Viton® is a registered trademark of DuPont™



ENGINEERING YOUR SUCCESS.

Application

FBO assemblies are specifically designed to meet the filtration requirements of today's high pressure common-rail diesel injection systems. The unit is used for fuel dispensing pumps or as a primary fuel filter/water separator on large diesel engine applications.

FBO-10 and FBO-14 filter assemblies were designed to meet the toughest conditions and offer ease of filter change outs. The FBO assembly can flow from 10 GPM (38 LPM) to 75 GPM (284 LPM), depending on which model, filter, and type of fuel to be filtered.

The assembly features a "locking ring collar", which attaches the filter housing to the aluminum die

cast filter head with four bolts. The slotted "locking ring collar" allows maintenance personnel to hand loosen the four collar bolts, rotate, and lower the bowl assembly for filter changeouts.

With a new filter cartridge installed, simply raise the bowl and rotate into position on the locking ring and hand tighten evenly (evenly torquing the 4 closure bolts to 100 lb-in is highly recommended).

The closure hardware consists of stainless steel nuts, bolts, and washers with metal hand knobs for ease of maintenance. No wrenches or other special tools are required, allowing one person to easily change the filter cartridge (no V-band clamps are used).

Biodiesel Filtration

FBO assemblies are great for biofuel applications because of ease of service, rugged construction, and the optional electric heater.

Biodiesel is known to attack certain synthetic rubber compounds so Viton o-rings are used to prevent o-rings from swelling, softening, shrinking, or hardening.

Racor recommends using a thermostatically controlled electric heater in the head and/or filter bowl to help avoid biofuel waxing and gelling. Pour point suppressants and biocides are necessary for reliable operation.



FBO Commercial Application



FBO Commercial Application



FBO Commercial Application

New Additions

New to the FBO family of filters are the Racor heavy duty Fuel Recycler Cart and the FBO Duplex Stand. The filter cart polishes, cleans up, and recycles old or contaminated fuel. It can be used in preventative maintenance as a servicing unit. The all aluminum construction keeps it lighter for mobility purposes, while being durable and corrosion resistant for many years of operation.

By popular demand the FBO Duplex Stand was designed with continuous duty applications in mind. The Duplex Stand assembly allows the isolation of one filter at a time for servicing while still in operation.



FBO Duplex Stand



FBO Filter Cart

Technical Information

Specifications	Maximum Flow Rates			Clean	Change
FBO-10	Diesel	Gasoline	Kerosene	Delta P	Delta P
Silicone Treated Filter	25 GPM (95 LPM)	53 GPM (200 LPM)	35 GPM (132 LPM)	2.5 PSID	15 PSID
Water Separator	20 GPM (76 LPM)	32 GPM (121 LPM)	21 GPM (79 LPM)	2.5 PSID	15 PSID
Water Absorber	20 GPM (76 LPM)	45 GPM (170 LPM)	35 GPM (132 LPM)	2.5 PSID	30 PSID
FBO-14	Diesel	Gasoline	Kerosene	Delta P	Delta P
Silicone Treated Filter	30 GPM (113 LPM)	75 GPM (284 LPM)	50 GPM (189 LPM)	2.5 PSID	15 PSID
Water Separator	25 GPM (95 LPM)	45 GPM (170 LPM)	30 GPM (113 LPM)	2.5 PSID	15 PSID
Water Absorber	25 GPM (95 LPM)	70 GPM (265 LPM)	55 GPM (208 LPM)	2.5 PSID	30 PSID

FBO Mounting Information

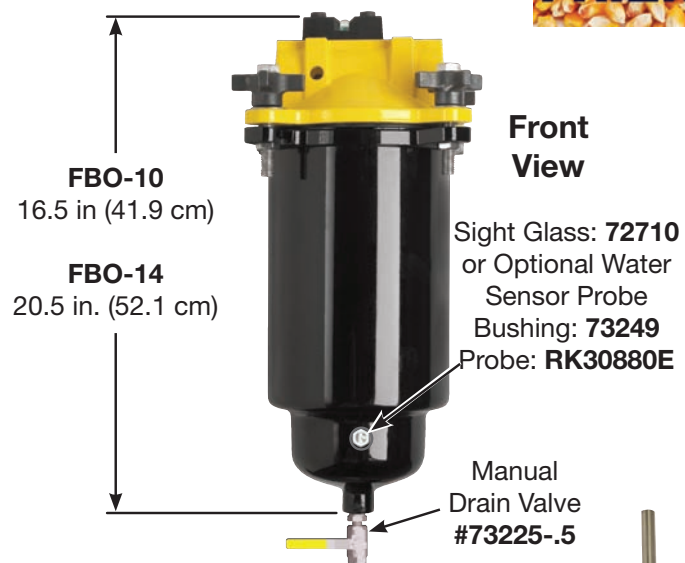
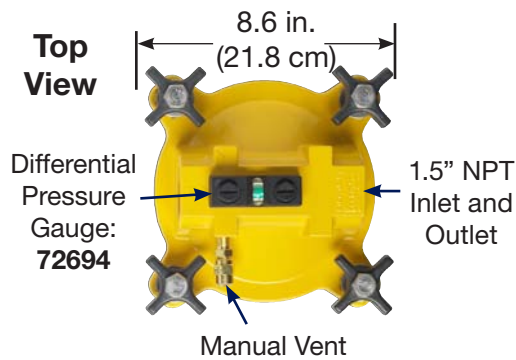

Mounting Bracket Hole Pattern

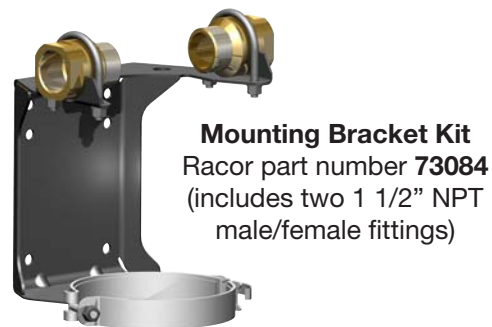
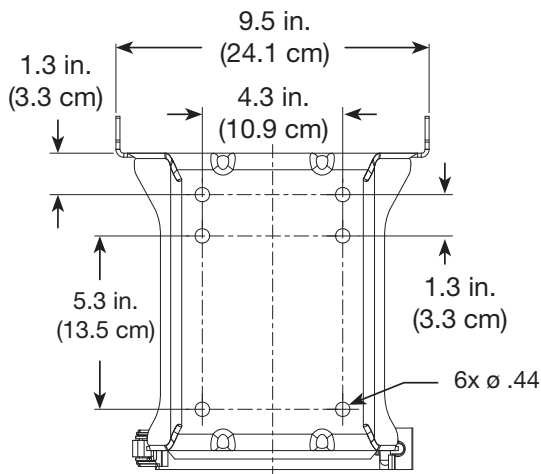

FBO-HTR-KIT

FBO Details

FBO-14-DPL-DUPLEX

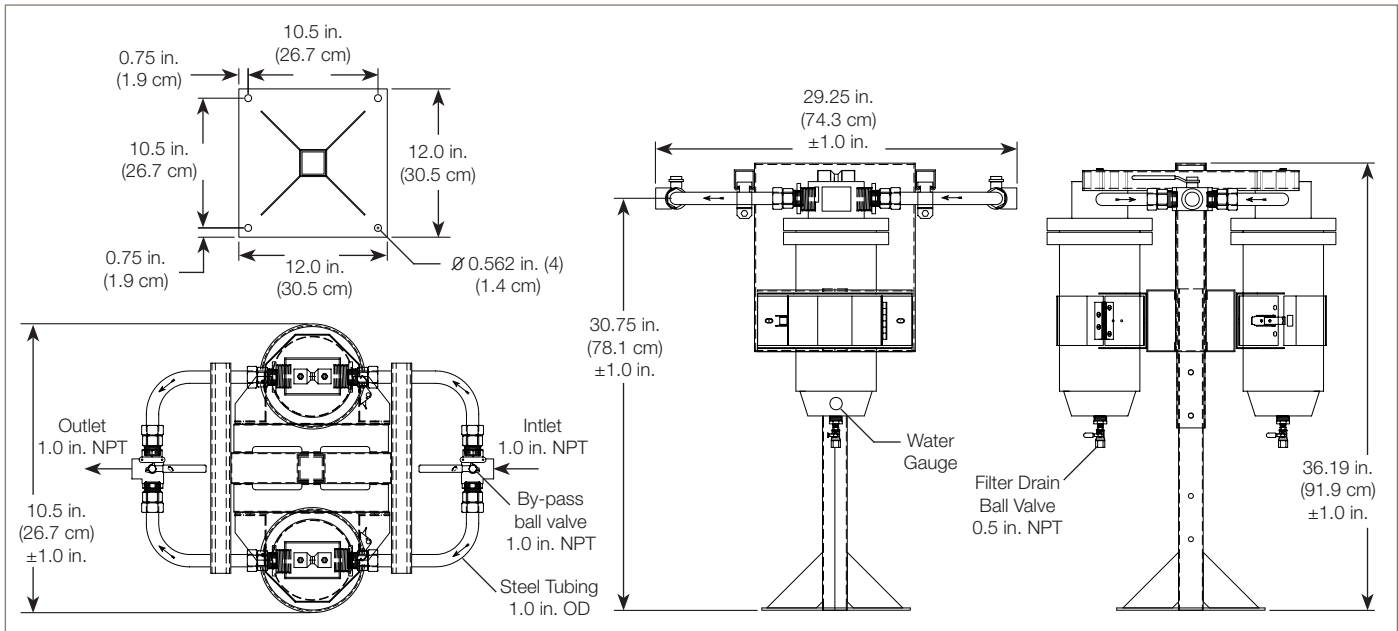

FC 20-1-120V

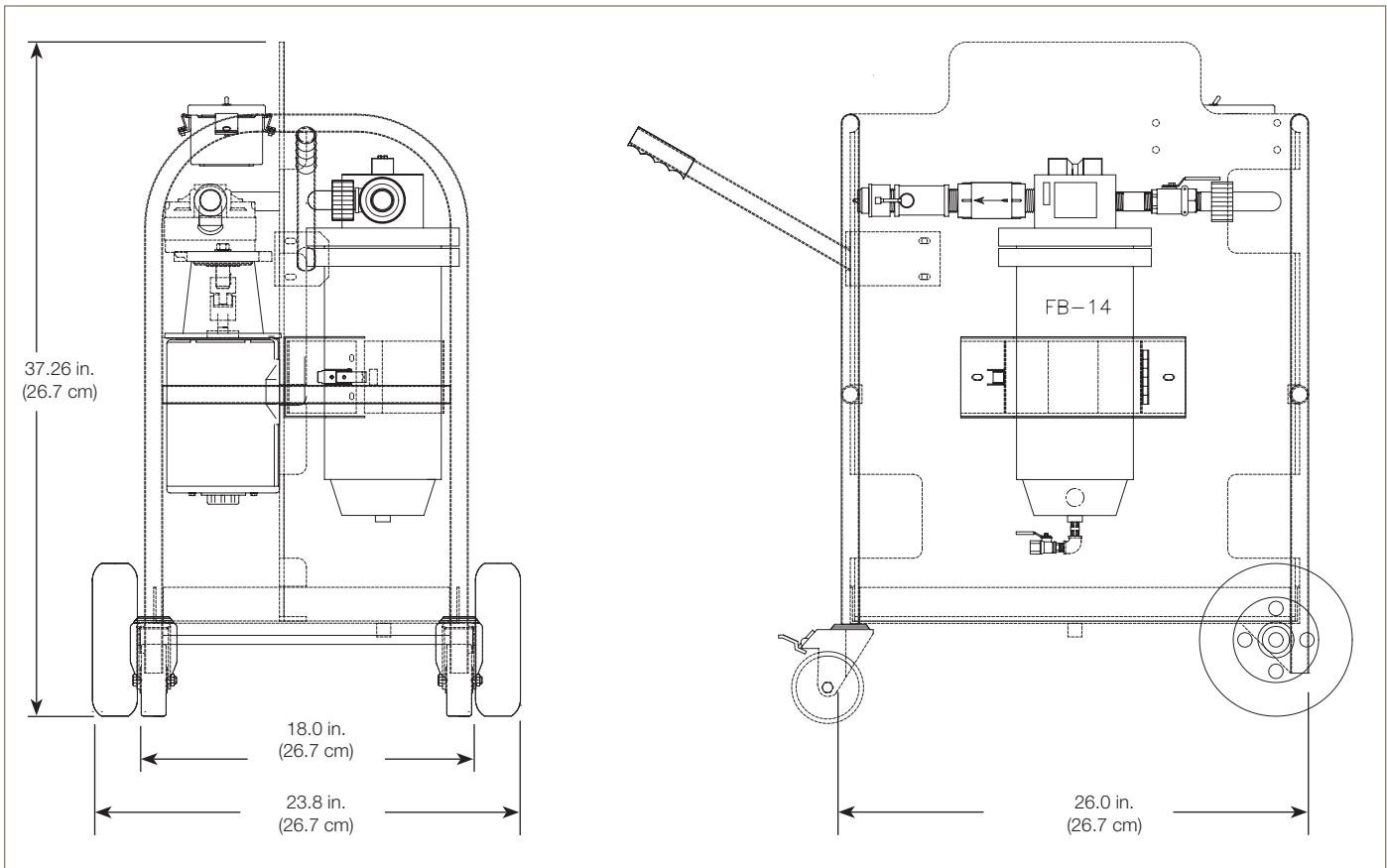

Replacement Filters

Filters are used to protect the OEM supplied fuel system.

Water Separator

Water separator filters remove water and contaminants from hydrocarbon fuel streams and are the most popular filters.

Silicone Treated

Silicone treated fuel filters remove particle contaminants down to one micron.



Silicone filters can also be used upstream, before a fuel filter/water separator, to extend filter life.

Water Absorber

Water absorber filters absorb water and filter out contaminants from diesel fuel and other hydrocarbon streams.



Filter Cartridge Chart

FBO	Micron Rating	Water Separator	Silicone Treated Filter	Water Absorber
 <p>FBO-10 (6 X 10 Element)</p>	1	FBO 60327 FBO 60360 ²	FBO 60330	FBO 60333
	5	FBO 60328	FBO 60331	FBO 60334
	10	FBO 60353	FBO 60354	FBO 60355
	25	FBO 60329	FBO 60332	FBO 60335
 <p>FBO-14¹ (6 X 14 Element)</p>	1	FBO 60336 FBO 60361 ²	FBO 60339	FBO 60342
	5	FBO 60337	FBO 60340	FBO 60343
	10	FBO 60356	FBO 60357	FBO 60358
	25	FBO 60338	FBO 60341	FBO 60344

¹ 72951 Monitor Adapter Plate enables the FBO-14 to take five, RMO-210-4 monitor elements.

² EI 1581 5th Edition filters are certified for jet fuel applications.

How to Order

Below is a guide to help order a FBO assembly with the accessories you need.

Assembly	Filter Cartridge (see previous page)	Delta P Gauge	Sight Glass	Drain Valve	Mounting Bracket
FBO-10	Order Separately				
FBO-10-DP	Order Separately	X			
FBO-10-DPL	Order Separately	X	X	X	
FBO-10-25M	FBO 60332	X	X	X	
FBO-10-HTR ¹	Order Separately	X	X	X	
FBO-14	Order Separately				
FBO-14-DP	Order Separately	X			
FBO-14-DPL	Order Separately	X	X	X	
FBO-14-25M	FBO 60341	X	X	X	
FBO-14-HTR ¹	Order Separately	X	X	X	
FBO-14-BKT-10F	FBO 60357	X	X	X	X
FBO-14-BKT-10FW	FBO 60358	X	X	X	X
FBO-14-BKT-10FWS	FBO 60356	X	X	X	X
FBO-14-BKT-25F	FBO 60341	X	X	X	X
FBO-14-BKT-25FW	FBO 60344	X	X	X	X
FBO-14-BKT-25FWS	FBO 60338	X	X	X	X
FBO-14-DPL-DUPLEX	Order Separately	X	X	X	

¹Note: Includes 120 volt AC explosion proof heater for stationary applications only.

Additional Information



The Racor mobile fuel polishing cart (FC-20-1-120V or FC-20-1-120V-KIT) are built with the robust FBO-14-DPL technology and are stocked and available. See brochure # 7872 for more details.

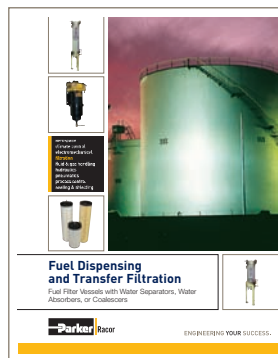

For more information of filtration in fuel dispensing applications, see brochure # 7648.

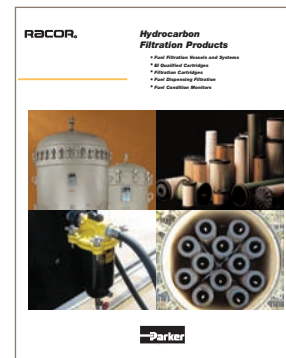

Additional information is available for high flow fuel filtration application in brochure # 7537.

Parker Filtration's Products and Systems



AEROSPACE

Key Products

- Filter Vessels (EI)
- Fluid Conditioning Monitors (Fuel & Hydraulic)
- Fuel Filter/Water Separators
- Fuel Inerting Systems (OBIGGS)
- Fuel Loading Filters (EI)
- Fuel, Hydraulic, & Lubrication Filters
- Nitrogen Tire Inflation Systems



FOOD & BEVERAGE

Key Products

- Carbon Dioxide Purifiers
- Compressed Air Dryers
- Fiber & Membrane Filters
- Nitrogen Generators
- Stainless Steel Filter Housings
- Steam & Sterile Air Filters
- Validation Test Equipment
- Water Chillers
- Water Filters



INDUSTRIAL & PLANT EQUIPMENT

Key Products

- ASME Coded Vessels
- Compressed Air Filters
- Condensate Management
- Contamination Monitoring
- Desiccant Dryers
- Membrane Filters & Dryers
- Refrigerated Dryers
- Hydraulic Filters
- Oil/Water Separators
- Process Filters
- Portable Hydraulic Systems



LIFE SCIENCES

Key Products

- Breathing Air Filters & Systems
- Chillers
- Compressed Air Filters
- Filter Integrity Analyzers
- Gas Sterilization Filters
- High Purity Gas Filters
- Hydrogen Gas Generators
- Nitrogen TriGas Systems
- Sterile Water Filters
- Syringe Filters



MARINE

Key Products

- Air Intake Filters
- ASME High Flow Vessels
- Crankcase Emission Filter Systems
- Fuel Dispensing Filters
- Engine Fuel Filter/Water Separators
- Engine Oil & Coolant Filters
- Gasoline Filters
- Hydraulic Filters
- Hydrocarbon Fluid Filters
- Oil/Water Separators
- Submarine CO₂ Reduction Units
- Water Desalination & Purification Systems



OIL & GAS

Key Products

- Air Intake Filters
- ASME High Flow Vessels
- Compressed Air Filters & Dryers
- Compressed Air Water Separators
- Crankcase Emission Filter Systems
- Engine Fuel Filter/Water Separators
- Engine Oil & Coolant Filters
- Fluid Condition Monitoring Systems
- Fuel Dispensing Filters
- Hydraulic Filters
- Hydrocarbon Fluid Filters
- Integrity Test Equipment
- Nitrogen Generators
- Mechanical Separators
- Membrane & Sterile Air Filters
- Oil/Water Separators



POWER GENERATION

Key Products

- Air Intake Filters
- ASME High Flow Vessels
- Bioenergy Water Chillers
- Crankcase Emission Filter Systems
- Engine Fuel Filter/Water Separators
- Fluid Condition Monitoring Systems
- Fuel Dispensing Filters
- Load Tap Filters
- Hydrogen Generators
- Magnetic Prefilters
- Nitrogen Generators
- Portable Hydraulic Systems
- Water Sensors

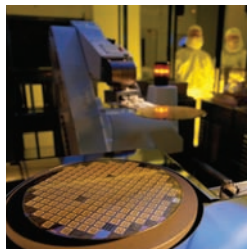

PROCESS

Key Products

- Alternative Gas Dryers & Absorbers
- Bag Filters
- Compressed Air Dryers
- Instrumentation Filters
- Nitrogen Generators
- Oil Absorption Filters
- Pleated Filter Cartridges
- Process Filters
- Semiconductor Filter Cartridges
- Stainless Steel Prefiltration Vessels
- Zero Air Generators



TRANSPORTATION & MOBILE EQUIPMENT

Key Products

- Air Intake Filters
- Alternative Fuel Filters
- ASME High Flow Vessels
- Crankcase Emission Systems
- Fuel Delivery Systems
- Fuel Dispensing Filters
- Fuel Filter/Water Separators
- Multi-stage Filter Systems
- High Pressure Natural Gas Filters
- Nitrogen Tire Inflation Systems
- Suction & Return Line Hydraulic Filters
- Transmission Filters
- Truck & Railway Dryers



WATER

Key Products

- Desalination & Purification Systems
- Oil Absorption Filters
- Oil/Water Separators
- Pleated Filter Cartridges
- Stainless Steel Prefiltration Vessels
- Sterile Water Filters

Parker Hannifin Corporation
Filtration Group
Global Headquarters
 6035 Parkland Boulevard
 Cleveland, OH 44124-4141
 T 216 896 3000, F 216 896 4021
www.parker.com

North America
Compressed Air Treatment
Filtration & Separation/Balston
 242 Neck Road
 Haverhill, MA 01835-0723
 T 978 858 0505, F 978 858 0625
www.parker.com/balston

Filtration & Separation/Finite
 500 Glaspie Street, PO. Box 599
 Oxford, MI 48371-5132
 T 248 628 6400, F 248 628 1850
www.parker.com/finitefilter

Purification, Dehydration and
Filtration Division
 4087 Walden Avenue
 Lancaster, NY 14086
 T 716 685 4040, F 716 685 1010
www.airtek.com

Sales Office
 5900-B Northwoods Parkway
 Charlotte, NC 28269
 T 704 921 9303, F 704 921 1960
www.domnickhunter.com

Engine Filtration &
Water Purification
Racor
 3400 Finch Road, PO Box 3208
 Modesto, CA 95353
 T 209 521 7860, F 209 529 3278
www.parker.com/racor
www.parker.com/racorproducts
www.racorcustomers.com

Racor
 850 North West St., PO Box 6030
 Holly Springs, MS 38635
 T 662 252 2656, F 662 274 2118

Racor
 302 Parker Drive
 Beaufort, SC 29906
 T 843 846 3200, F 843 846 3230

Racor -- Village Marine Tec.
 2000 West 135th Street
 Gardena, CA 90249
 T 310 516 9911, F 310 538 3048
www.villagemarine.com

Hydraulic Filtration
Hydraulic Filter
 16810 Fulton County Road #2
 Metamora, OH 43540-9714
 T 419 644 4311, F 419 644 6205
www.parker.com/hydraulicfilter

Process Filtration
Process Advanced Filtration
 2340 Eastman Avenue
 Oxnard, CA 93030
 T 805 604 3400, F 805 604 3401
www.parker.com/processfiltration

© Parker Hannifin Corporation
 7589 Rev D (Oct 2010)

Europe
Compressed Air Treatment
domnick hunter Industrial
 Dukesway, Team Valley Trading Estate
 Gateshead, Tyne & Wear
 England NE11 0PZ
 T +44 (0) 191 402 9000,
 F +44 (0) 191 482 6296
www.domnickhunter.com

Hiross Zander
Padova Business Unit
 Strada Zona Industriale 4
 35020 S. Angelo di Piove Padova, Italy
 T +39 049 9712 111, F +39 049 9701 911
www.dh-hiross.com

Hiross Zander
Essen Business Unit
 Zander Aufbereitungstechnik GmbH
 Im Teelbruch 118
 D-45219 Essen, Germany
 T +49 2054 9340, F +49 2054 934164
www.zander.de

Parker Gas Separations
 Oude Kerkstraat 4
 P O Box 258
 4870 AG Etten- Leur, Netherlands
 T +31 76 508 5300, F +31 76 508 5333

Engine Filtration &
Water Purification

Racor
 Shaw Cross Business Park
 Churwell Vale Dewsbury,
 WF12 7RD England
 T +44 (0) 1924 487000,
 F +44 (0) 1924 487038
www.parker.com/rfde

Racor Research & Development
 Parker Hannifin GmbH & Co KG
 Inselstrasse 3 – 5
 70327 Stuttgart Germany
 T +49 (0)711 7071 290-0,
 F +49 (0)711 7071 290 -70
www.parker.com/racor

Hydraulic Filtration
Hydraulic Filter
 Stieltjesweg 8, 6827 BV
 P.O. Box 5008 6802 EA
 Arnhem, Holland
 T +31 26 3760376, F +31 26 3643620
www.parker.com/eurofilt

Urjala Operation
 Salmentie 260
 31700 Urjala as Finland
 T +358 20 753 2500, F +358 20 753 2501
www.parker.com/fi

Condition Monitoring Center
 Brunel Way Thetford,
 Norfolk IP 24 1HP England
 T +44 1842 763299, F +44 1842 756300
www.parker.com/cmc

Process Filtration
domnick hunter Process
 Durham Road, Birtley Co. Durham,
 DH3 2SF England
 T +44 (0) 191 410 5121,
 F +44 (0) 191 410 5312
www.domnickhunter.com

Asia Pacific
Australia
 9 Carrington Road, Castle Hill
 NSW 2154, Australia
 T +61 2 9634 777, F +61 2 9899 6184
www.parker.com/australia

China
 280 YunQiao Road
 JinQiao Export Processing Zone
 Shanghai 101206 China
 T +86 21 5031 2525, F +86 21 5834 3714
www.parker.com/china

India
 Plot EL 26, MIDC, TTC Industrial Area
 Mahape, Navi Mumbai 400 709 India
 T +91 22 5613 7081, 82, 83, 84, 85
 F +91 22 2768 6618 6841
www.parker.com/india

Japan
 626, Totsuka-cho, Totsuka-ku
 Yokohama-shi, 244-0003 Japan
 T +81 45 870 1522, F +81 45 864 5305
www.parker.com/japan

Korea
 1-C Block, Industrial Complex of Jangan,
 615-1, Geumui-Ri Jangan-Myeon,
 Hwaseong-City Gyeonggi-Do, Korea
 T +82 31 359 0771, F +82 31 359 0770
www.parker.com/korea

Singapore
 11, Fourth Chin Bee Road
 Singapore 619 702
 T +65 6887 6300, F +65 6261 4929
www.parker.com/singapore

Thailand
 1023 3rd Floor, TPS Building
 Pattanakam Road, Suanluang,
 Bangkok 10250 Thailand
 T +66 2717 8140, F +66 2717 8148
www.parker.com/thailand

Latin America
Parker Comercio Ltda.
Filtration Division
 Estrada Municipal Joel de Paula
 900 Eugenio de Melo,
 Sao Jose dos Campos
 CEP 12225390 SP Brazil
 T +55 12 4009 3500, F +55 12 4009 3529
www.parker.com/br

Pan American Division - Miami
 7400 NW 19th Street, Suite A
 Miami, FL 33128
 T 305 470 8800 F 305 470 8808
www.parker.com/panam

Africa
Parker Hannifin Africa Pty Ltd
 Parker Place, 10 Berne Avenue,
 Aeroport Kempton Park,
 1620 South Africa
 T +27 11 9610700, F +27 11 3927213
www.parker.com/eu

